

Transaction flow of ICD

**A. Own Account Deposit: Cash deposit for crediting cardholder's own account**

**(i) Validation Leg**

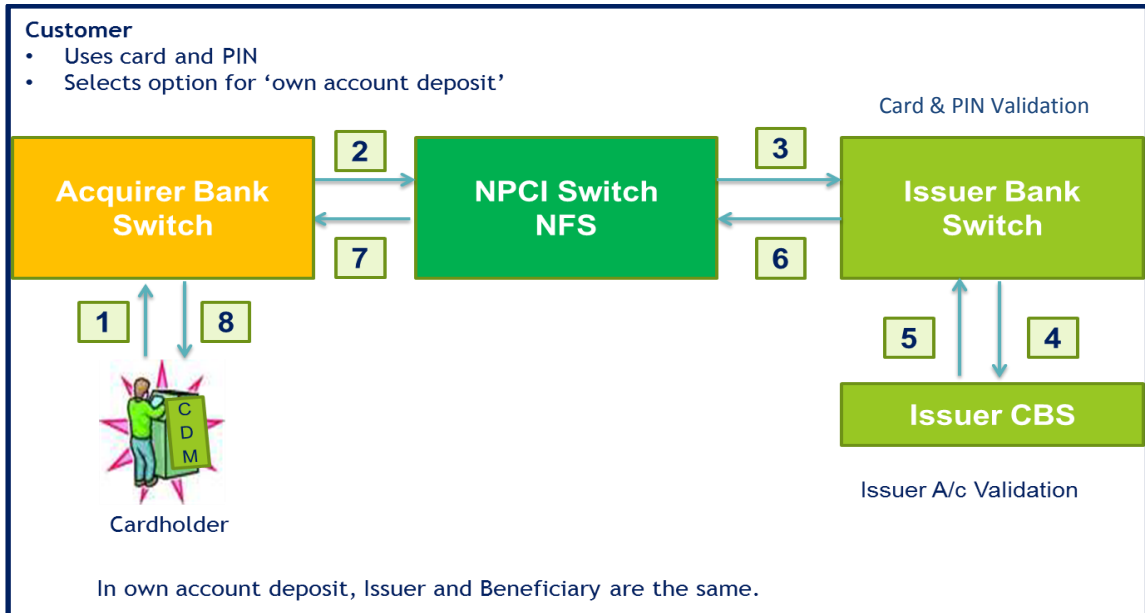

**Fig.1**

**(ii) Deposit Leg**

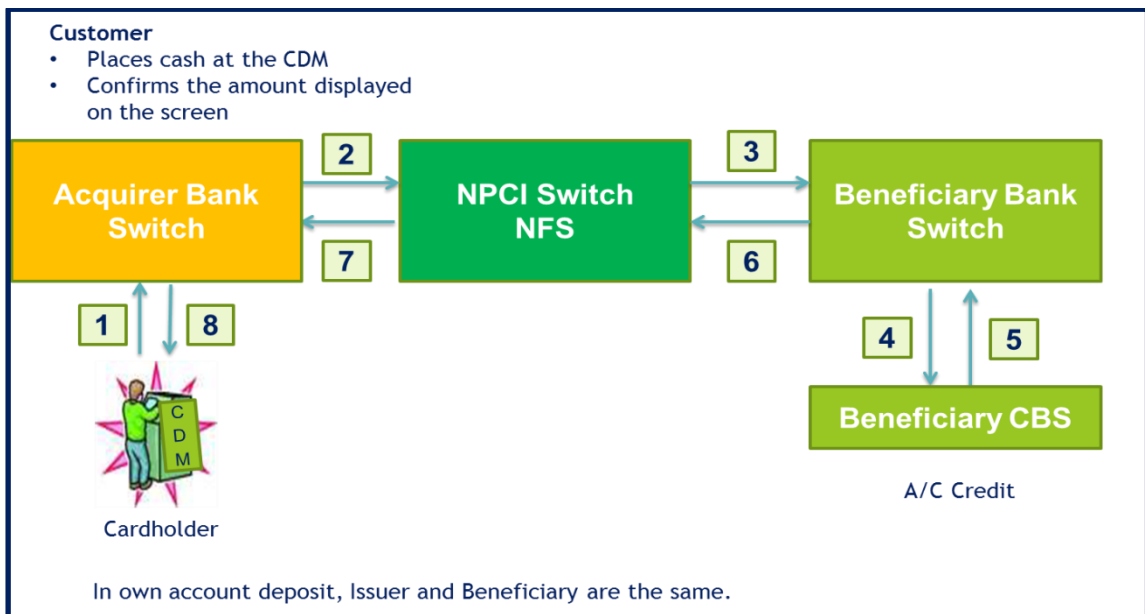

**Fig. 2**

**B. Third Party Account Deposit: Cash deposit for crediting third party account.**

**(i) Validation Leg**

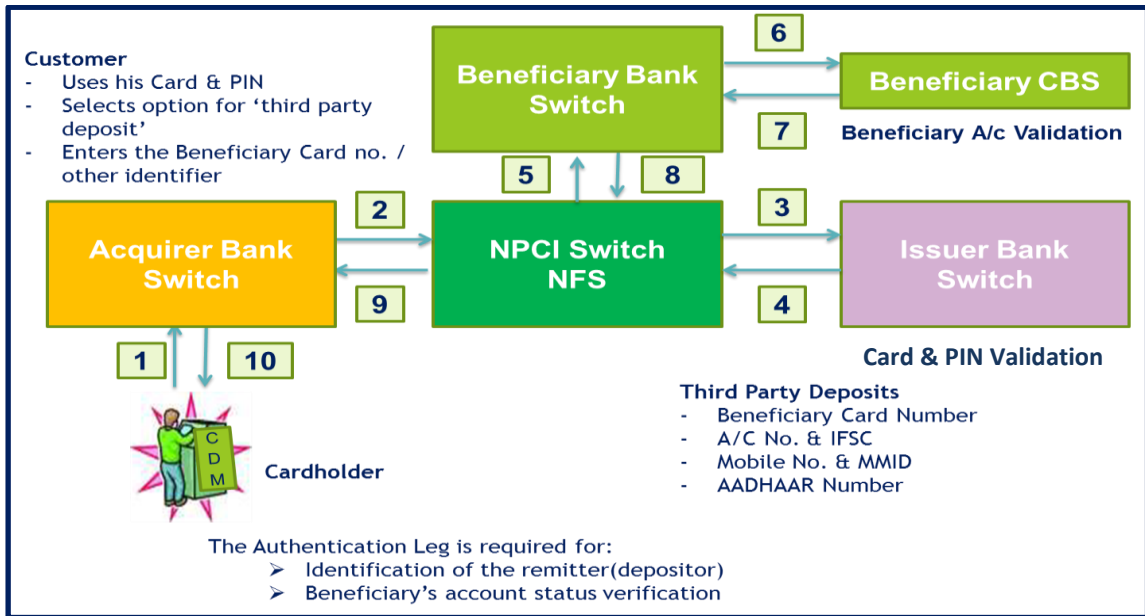

**Fig.3**

**(ii) Deposit Leg**

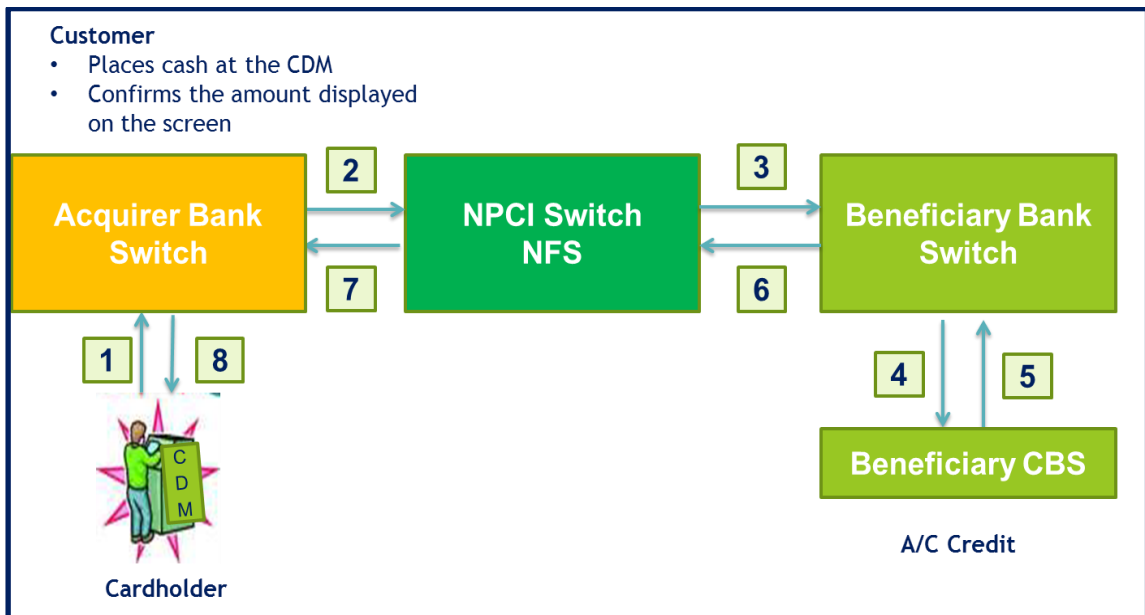

**Fig.4**

**Note:** In case of Beneficiary time out i.e. leg 6 in Fig.2 & Fig.4 above is not received by NPCI, it shall be treated as 'deemed successful' transaction with response code (RC) as '71' for the deposit leg (credit to beneficiary account).